

Cesium Ion-Beam Neutralization with Energetic Electrons

GEORGE C. THEODORIDIS* AND ELIAS P. GYFTOPOULOS†
Massachusetts Institute of Technology, Cambridge, Mass.

The neutralization of the positive space charge of cesium ion beams of energies up to 2500 ev by means of energetic electrons (of the order of 100 ev) is investigated experimentally. It is found that neutralization occurs provided that electrons are supplied at the same rate as the ions. The results are independent of any other parameter of the electron beam. An attempt is made to justify the observed experimental results by means of a two-stream collective scattering interaction between the energetic electrons and the ion-beam plasma. The one-dimensional dispersion relation for this interaction indicates the existence of growing longitudinal oscillations under the conditions prevailing in the experiments. These oscillations may be the mechanism by which the electron drift energy is thermalized, thus leading to the observed neutralization. The results of this work suggest that neutralizing electrons can be introduced into the ion beam of an ion-propelled spaceship by means of an electron gun instead of being made available by placing a hot electron source in the vicinity of the ion beam. Through use of an electron gun, the electron current can be controlled continuously, and the electron emitter can be well protected.

I. Introduction

THE purposes of this paper are to present experimental results on the neutralization of cesium ion beams of energy from 500 to 2500 ev by means of electrons of energies up to a few hundred ev and to interpret the experimental observations by means of a two-stream collective scattering interaction between the electrons and the resulting plasma. The problem of space charge neutralization is of import to ion propulsion. In some laboratory experiments, the beam is neutralized by extracting electrons from hot filaments or plates placed in the immediate vicinity or inside the ion beam.¹⁻³ The extraction is achieved by the potential of the beam. In other experiments,^{4,5} electrons are injected transversely into the ion beam by means of electron guns. An electron trap is established around the region of injection, using appropriately biased electrodes. The electrode potentials are adjusted so that, at the ion-beam exhaust, the longitudinal electron-velocity component is approximately equal to the ion velocity.⁴

In the present work, electrons are injected along the ion beam by means of an electron gun placed around the ion-beam exit. It is found experimentally and justified theoretically that these electrons are capable of neutralizing the positive space charge even though they are originally relatively very energetic. The paper is organized as follows: the experimental equipment and procedures are discussed in Sec. II, the experimental data are presented in Sec. III, and a theoretical justification of the results is given in Sec. IV.

II. Experimental Equipment and Procedures

All of the experiments are performed with a surface ionization cesium ion source, schematically shown in Fig. 1. Ions are formed on the surface of the porous tungsten ionizer that is kept at about 1500°K by means of an electron bombardment heater and at a positive potential V_i . The area of the ionizer is approximately 1 cm². The ions are accelerated by means of the accelerating grid, which is placed 3 to 5 mm

away from the ionizer and kept at a potential V_a . Electrons are injected into the beam by means of the electron gun, which surrounds the ionizer. They emerge as a cylindrical ring surrounding the ion beam. The electron filament is biased to a potential V_f , and the electron acceleration is achieved by means of the same grid as that for the ions. All of the potentials are measured with respect to the walls of the vacuum chamber.

The ion source operates in a 30 × 35 × 90-cm vacuum chamber at a pressure of the order of 2×10^{-6} torr. Figure 2 is a schematic of the arrangement of the copper current collectors for monitoring the beam in the chamber. The main collector *A* is a disk, 20 cm in diameter and 70 cm away from the source. The auxiliary collectors *B* through *F* are L-shaped, 12-cm wide strips extending over half of the perimeter of the walls. The collectors are kept at ground potential, but they are electrically insulated from each other. The grid *G* forms a closed surface all around the ion source and is biased to a voltage V_g , which determines the potential around the beam. In addition, there are two other grids G_a and G_e , which are used to control secondary emission from the corresponding collectors *A* and *C*. These two grids are kept at the same potential V_s .

The ion source is capable of supplying currents of the order of tens of milliamperes. The various accelerating and bias voltages are of the following order of magnitude: $V_i - V_a \approx 500 \div 2000$ v, $V_a - V_f \approx 100$ v, $V_g \approx 300$ v, $V_s \approx -200$ v.

The experiments are performed by applying the ionizer voltage as a fast rising step (pulse) and monitoring the temporal behavior of the currents arriving at the various collectors. The reason for the pulsed operation is as follows. When the ion source is operated under steady-state conditions, and without a deliberately introduced electron emitter, the ion beam does not appear to experience any space charge effects.⁶ This is because of the fact that electrons are ob-

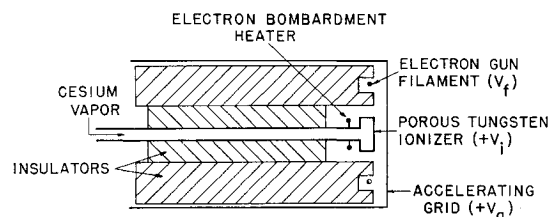

Fig. 1 Schematic of cesium ion source and electron gun.

Received August 3, 1964; revision received April 28, 1965. This work was supported in part by the U. S. Army, Navy, and Air Force, under Contract DA36-039-AMC-03200(E), and in part by the National Science Foundation (Grant G-24073).

* Nuclear Engineering Department and Research Laboratory of Electronics; now with American Science and Engineering, Inc., Cambridge, Mass.

† Associate Professor, Nuclear Engineering Department and Research Laboratory of Electronics. Member AIAA.

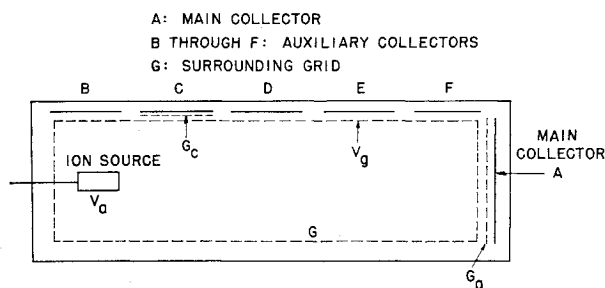

Fig. 2 Schematic of vacuum chamber and current collector.

tained from the boundaries by secondary emission. The electrons are trapped in the beam and result in the neutralization of the positive space charge. The spurious self-neutralization will not be present in free space. Therefore, the effectiveness of any neutralization scheme must be tested in the laboratory only over periods of time shorter than the time necessary for self-neutralization by secondary emission electrons (hence the pulsed experiments described in the subsequent section).

III. Experimental Results

In one series of experiments, the ionizer voltage is applied as a step with a rise time of less than 0.2 μsec , and the filament of the electron gun is off. The resulting positive currents at the various collectors have the patterns shown in Fig. 3. After a time t_i approximately equal to the theoretical single-ion transit time between the source and the main collector, a small current appears on this collector (Fig. 3a). As time progresses, the positive space charge is being neutralized, and the current increases. It reaches, say, 80% of its final value at time t_n . During the neutralization time t_n , current pulses appear on the auxiliary lateral collectors (Fig. 3b). The time sequence of the pulses is consistent with the geometrical location of the collectors (Fig. 2).

The meaning of these current patterns is that, initially, the ions diverge toward all of the walls under the influence of space charge. As time goes on, secondary emission electrons neutralize the space charge and result in a fairly collimated ion beam from the source to the main collector.

The neutralization time t_n depends very strongly upon the cesium ion energy. For ion energies around 500 eV, t_n is about 200 times longer than the theoretical transit time t_i .[†] For energies greater than 1500 eV, t_n is only about twice as long as t_i . This behavior is to be expected. The secondary emission coefficient, which determines the rate at which

Table 1 $V_a = 200 \text{ v}$, $V_g = 300 \text{ v}$, $V_f = 100 \text{ v}$

V_i , v	Neutralization time t_n , μsec		Theoretical transit time, μsec
	Electron gun off	Electron gun on	
550	6500	45	36
650	1000	40	30
800	150	28	25
950	100	25	22
1100	60	23	20
1250	43	20	19
1500	33	18	16.5
2000	25	15	14
2500	23	14	12.5

[†] It is obvious that both the neutralization and the theoretical transit times are approximate quantitative measures of the phenomena in question. They are selected arbitrarily for convenience and in order to describe the experiments in a consistent fashion.

Fig. 3 Current pattern: a) on collector A; and b) on collectors B through F when the electron gun is off, and the voltage on the ionizer is applied as a step at time $t = 0$.

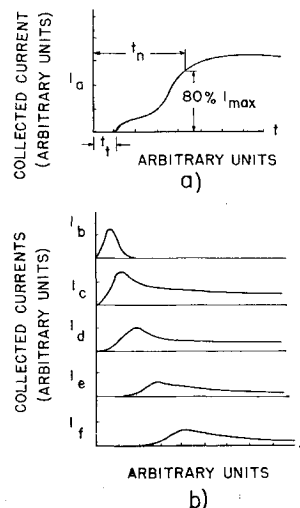

electrons are obtained from the boundaries, is a strong function of the ion energy.⁷

In another series of experiments, the ionizer voltage is applied as a step with the electron gun filament on. The observed current patterns are similar to those of Fig. 3. However, the neutralization time is much shorter. Table 1 is a list of neutralization times measured with the electron filament off and on for different ion energies and an electron energy of 100 eV. The table also includes the calculated single-ion transit time from the source to the main collector. This time is calculated on the basis of the average ion energy between the accelerating grid and the collector. It is evident that the presence of the electrons reduces the neutralization time practically to the transit time, which is the shortest time the ions need to reach collector A.[§]

In still another series of experiments, the neutralization time is measured under similar conditions but with the magnitude of the electron current as a variable. Figure 4 is a summary of the results. It is observed that, when the electron current is equal to the available ion current, the neutralization time is approximately equal to the ion transit time. Further increase in the electron current does not cause an appreciable decrease in t_n . Consequently, as soon as the electrons are supplied at the same rate as the ions, the space charge is neutralized, and the delay in the beam arrival at collector A is eliminated.

The preceding results do not depend upon any other factors besides the presence of the electrons. The measured neutralization times are the same regardless of whether the electron current is flowing continuously, and the ion current is pulsed, or whether both the electron and ion currents are pulsed at the same time.

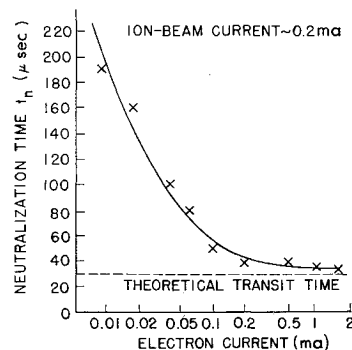

Fig. 4 Neutralization time t_n vs electron gun current for $V_i = 600 \text{ v}$, $V_a = 200 \text{ v}$, $V_g = 300 \text{ v}$, and $V_f = 100 \text{ v}$.

[§] It should be noted that equality of the neutralization and transit times is not a necessary measure of the effectiveness of a neutralization mechanism. The reason is that any neutralization process requires a finite transit period for its establishment

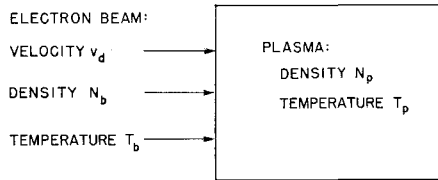

Fig. 5 Theoretical model for investigation of the two-stream collective scattering interaction.

From the data of Table 1 and Fig. 4, it is seen that the electrons have an energy in excess of 100 eV. The electron speed corresponding to this energy is much larger than that of the ions. For equal electron and ion currents, the electron density computed from the electron current and energy is not adequate to neutralize the ion space charge. The fact that neutralization is achieved suggests that there must be a mechanism by means of which the directed energy of the electrons is thermalized so that they remain in the region of the ion beam long enough to neutralize it. Such a mechanism is discussed in the next section.

IV. Theoretical Interpretation

The directed electron energy can be thermalized if the electrons are scattered extensively in the region of the ion beam. Scattering by individual particles is far too weak to result in any substantial thermalization. It is proposed that the electrons are thermalized by means of a two-stream collective scattering interaction with the plasma that is established in the region of the ion beam.⁸ This interaction excites longitudinal oscillations at the expense of the drift energy.

In order to investigate the likelihood of the proposed interaction, the experiment is simulated by the one-dimensional model shown in Fig. 5. The electron beam has a density N_b , a drift energy $\frac{1}{2}mv_d^2$, and a superimposed thermal agitation characterized by a temperature T_b (Maxwellian distribution). The cesium plasma has a density N_p and an electron temperature T_p . The temperature $T_p \gg T_b$ because, when the incoming beam excites plasma oscillations, most of the drift energy is transferred to the plasma electrons rather than the ions. In fact, to a good approximation, $kT_p = \frac{1}{3}mv_d^2$, provided that all of the drift energy is thermalized. On the basis of this model, the dispersion relation for longitudinal waves is examined and found to admit solutions, which correspond to growing fluctuations.

Indeed, suppose that the interaction between the electron beam and the plasma results in a fluctuating electric field of the form $A \exp[i(\omega t - \alpha x)]$. Thus, Poisson's equation and the equations of particle motion and continuity yield the dispersion relation^{8,9}

$$\omega_b^2 \int_{-\infty}^{\infty} \frac{f_b(v - v_d)}{(\omega - \alpha v)^2} dv + \omega_p^2 \int_{-\infty}^{\infty} \frac{f_p(v)}{(\omega - \alpha v)^2} dv = 1 \quad (1)$$

where $\omega_b^2 = 4\pi e^2 N_b/m$, e is the electronic charge, and $f_b(v - v_d)$ and $f_p(v)$ are the velocity distribution functions of the beam and plasma electrons, respectively. Integration of Eq. (1) by parts yields

$$\frac{N_b}{N_p} \int_{-\infty}^{\infty} \frac{f_b'(v - v_d)}{v - (\omega/\alpha)} dv + \int_{-\infty}^{\infty} \frac{f_p'(v)}{v - (\omega/\alpha)} dv = \frac{\alpha^2}{\omega_p^2} \quad (2)$$

where the prime indicates differentiation with respect to v . For Maxwellian distributions, Eq. (2) can be written as

$$(N_b T_p / N_p T_b) g(z_b) = \lambda_p^2 \alpha^2 - g(z_p) \quad (3)$$

where

$$g(z) = -\pi^{-1/2} \int_{-\infty}^{\infty} \frac{q \exp(-q^2)}{q - z} dq \quad (4)$$

$$z_b = [(\omega/\alpha) - v_d] / (2kT_b/m)^{1/2} \quad (5)$$

$$z_p = (\omega/\alpha) / (2kT_p/m)^{1/2} \quad (6)$$

$$\lambda_p = kT_p / [m\omega_p^2]^{1/2} \quad (7)$$

The function $g(z)$, defined by Eq. (4), is calculated in Ref. 9. For convenience, some contour plots of this function are reproduced in Fig. 6. The solid-line heart-shaped contour corresponds to z real. All of the values of $g(z)$ for $Imz < 0$ lie inside the solid-line contour, and all of the values for $Imz > 0$ lie outside this contour.

The assumed fluctuations grow at the expense of the electron drift energy when there exist real positive values of α for which the dispersion relation (3) admits complex solutions ω with a negative imaginary part. To establish the condition under which this is true, the left- and right-hand sides of Eq. (3) are plotted in Fig. 7 for arbitrary values of $N_b T_p / N_p T_b$ and $\lambda_p^2 \alpha^2$. In addition, Eqs. (5) and (6) are written as

$$Im(\omega/\alpha) / (2kT_p/m)^{1/2} = Imz_p = (T_b/T_p)^{1/2} Imz_b \quad (8)$$

$$(mv_d^2 / 2kT_p)^{1/2} = (\frac{3}{2})^{1/2} = Rez_p - (T_b/T_p)^{1/2} Rez_b \quad (9)$$

Inspection of Eqs. (8) and (9) and Fig. 7 suggests that, for solutions with $Im(\omega/\alpha) < 0$ to exist, the following requirements must be satisfied: 1) $Imz_b < 0$, $Imz_p > 0$; 2) the contours of Fig. 7 for z_b and z_p real must overlap; 3) $Rez_b < 0$, $|Rez_b| < (3T_p/2T_b)^{1/2}$, $0 < Rez_p < (\frac{3}{2})^{1/2} \approx 1.2$; and 4) for $T_p \gg T_b$, the $g(z_b)$ region of interest, as defined in requirements 1 and 3, corresponds to a small region around $g(z_p)$ for $z_p \approx Rez_p \approx 1.2$. Therefore, the overlapping of contours for z_b and z_p real leads to common values for the left- and right-hand sides of Eq. (3) with $Im(\omega) < 0$, $\alpha > 0$ if

$$(N_b T_p / N_p T_b) > g(z_p = 1.2) / g(z_b = z_{b1}) \approx 0.7 \quad (10)$$

where the point z_{b1} is defined on the $g(z_b)$, z_b real contour such that the vectors $g(z_p = 1.2)$ and $g(z_b = z_{b1})$ are parallel.

Inequality (10) is the essential condition that must be satisfied for diverging fluctuations to develop. In the experiments, the electron beam energy is about 100 eV, and the thermal spread of the beam is equal to the electron emitter temperature ($\sim 2400^\circ\text{K}$) so that $\frac{3}{2}kT_b = 0.2$ eV. Consequently,

$$T_p/T_b \approx 500 \quad (11)$$

since it is assumed that $\frac{3}{2}kT_p = \frac{1}{2}mv_d^2$. The electron and ion currents are approximately equal, and the cesium ion energies range from 500 to 2000 eV. If, for simplicity, both the electron and ion-beam cross-sectional areas are taken as equal, then

$$N_b/N_p = [(E_i/M)/(E_e/m)]^{1/2} = \frac{1}{200} \text{ to } \frac{1}{100} \quad (12)$$

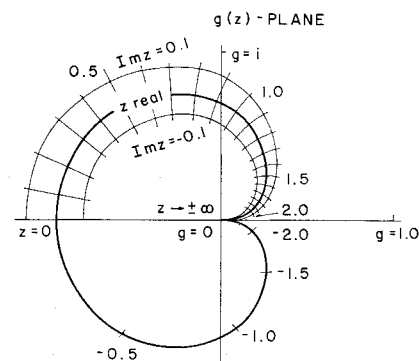

Fig. 6 Plot of the function $g(z)$ defined by Eq. (4).

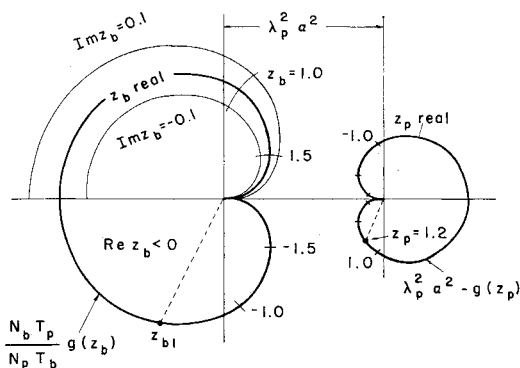

Fig. 7 Plot of the two sides of Eq. (3).

Thus, for the conditions prevailing in the experiments,

$$N_b T_p / N_p T_b = 2.5 \text{ to } 5 \quad (13)$$

In other words, inequality (10) is satisfied, and longitudinal fluctuations are excited at the expense of the electron beam drift energy. Of course, in order to account for the complete transfer of the drift energy to the plasma electrons, the excited oscillations must grow beyond the limits where the dispersion relation approach (linearized equations) is applicable. Nevertheless, the preceding results indicate that a two-stream collective scattering interaction may be the mechanism by which the electron drift energy is thermalized, and the experimentally observed neutralization is achieved. In this regard, it is worth noting that the estimate of the ratio $N_b T_p / N_p T_b$ [Eq. (13)] is conservative because the cross-sectional area of the electron beam is much smaller than that of the ion beam. Additional experimental evidence supporting the proposed mechanism is the presence of radio frequency oscillations observed by Bernstein¹⁰ in a neutralized ion beam.

V. Conclusions

Experiments performed with a pulsed cesium ion beam of energies up to 2500 eV indicate that the positive ion space charge can be effectively neutralized by injection of energetic electrons (of the order of 100 eV) into the beam region. The results imply the existence of a mechanism by means of which the directed electron energy is thermalized so that the

electron space charge becomes equivalent to that of the ions.

A linear one-dimensional analysis shows that a two-stream collective scattering interaction between the injected electrons and the neutralizer beam (plasma) is probably responsible for the thermalization of the electron drift energy.

The results of this work suggest that neutralizing electrons can be introduced by means of an electron gun into the ion beam of an ion-propelled spaceship without any special effort to match the ion and electron velocities as has been always deemed essential in previous neutralizer designs. Through use of an electron gun, the electron current can be controlled continuously, and the electron emitter can be well protected.

References

- Sellen, J. M. and Kemp, R. F., "Cesium ion beam neutralization in vehicular simulation," ARS Preprint 61-84-1778 (1961).
- Kemp, R. F. and Sellen, J. M., "Beam neutralization tests of a flight model electron bombardment engine," ARS Preprint 2663-62 (1962).
- Cybulski, R. J. and Lockwood, D. L., "An experimental evaluation of a two-dimensional ion engine with charge neutralization," ARS Preprint 61-82-1776 (1961).
- Etter, J. E., Eilenberg, S. L., Currie, M. R., and Brewer, G. R., "Neutralization of ion beams," *AIAA Progress in Astronautics and Aeronautics: Electrostatic Propulsion*, edited by D. B. Langmuir, E. Stuhlinger and J. M. Sellen Jr. (Academic Press, New York, 1961), pp. 357-372.
- Ward, J. W. and Hubach, R. A., "Neutralization of ion beams from engines of annular geometry," ARS J. **32**, 1730 (1962).
- Sellen, J. M. and Shelton, H., "Transient and steady state behavior in cesium ion beams," *AIAA Progress in Astronautics and Aeronautics: Electrostatic Propulsion*, edited by D. B. Langmuir, E. Stuhlinger, L. M. Sellen Jr. (Academic Press, New York, 1961), pp. 305-356.
- Rose, D. J. and Clark, M., *Plasmas and Controlled Fusion* (John Wiley and Sons, New York, 1961), p. 49.
- Bohm, D. and Gross, E. P., "Theory of plasma oscillations," Phys. Rev. **75**, 1851, 1864 (1949).
- Buneman, O., "Dissipation of currents in ionized media," Phys. Rev. **115**, 503 (1959).
- Bernstein, W. and Sellen, J. M., "Oscillations in synthetic plasma beams," Phys. Fluids **6**, 1032 (1963).